



# LED Solar Area Light

## BRIGHTEN YOUR LIFE

NEW LED TECHNOLOGY THAT ALLOWS THE  
COEXISTENCE OF ENVIRONMENTAL  
PROTECTION AND ENERGY SAVING

### Benefits

1. Replace conventional Area Lights
2. Precision Die Cast Aluminum Housing
3. Fade Resistant Powder Coat Finish
4. Easy Installation
5. CE ROHS listed



15W  
20W  
25W

BB-SLD-XXX-AR-B1



20W  
25W  
40W

BB-SLD-XXX-AR-B2



50W  
80W  
100W

BB-SLD-XXX-AR-B3

## Features

1. Beam angle:120 degrees.
2. Aluminum die-casting heat sinks is good for heat dissipation.
3. It's major to replace the conventiona area light.
4. Green, energy saving, long and reliable life of 50,000 hours.
5. No RF interference, No IR/UV radiation ,no mercury pollution.
6. Wide colour availability in degrees Kelvin(K),2700-6700K.
7. Streamline exterior design, beautiful appearance.
8. Environment friendly ,energy saving (70~80%).
9. Special circuit design, each LED work separately,  
avoiding the single broken LED influence problem.



## Application

- 1.Area roadway/roadway lighting.
- 2.Parking areas lighting.
- 3.Airports lighting.
- 4.Streetscapes lighting.
- 5.Campuses lighting.



# SPECIFICATIONS

LED MAX Power	15W	20W	25W	20W	25W	40W	50W	80W	100W
Model	BB-SLD-15W-AR-B1	BB-SLD-20W-AR-B1	BB-SLD-25W-AR-B1	BB-SLD-20W-AR-B2	BB-SLD-25W-AR-B2	BB-SLD-40W-AR-B2	BB-SLD-50W-AR-B3	BB-SLD-80W-AR-B3	BB-SLD-100W-AR-B3
Solar panel Max power	18V/18W	18V/27W	18V/30W	18V/27W	18V/30W	18V/45W	18V/60W	18V/100W	18V/120W
Luminous Flux	2250lm	2400lm	3000lm	3000lm	3750lm	5000lm	7500lm	9600lm	12000lm
Luminous Efficacy	150lm/w	120lm/w	120lm/w	150lm/w	150lm/w	120lm/w	150lm/w	120lm/w	120lm/w
Mounting Height	3-4m	3-5m	3-5m	3-5m	3-5m	6-7m	8-9m	9-10m	9-10m
Space Bettwen Light	5-10m	10-15m	10-15m	10-15m	10-15m	15-20m	20-30m	30-40m	40-50m
Solar Panel Dimension	Dia405*41mm			Dia540*41mm			Dia850*41mm		
Sensor	Default:PIR Sensor&Time Controller together.								
Controller	PWM controller, MPPT controller optional								
Battery	Ternary Li-ion battery, LiFePO4 battery optional								
Discharge Time	More than 10-12hours								
Charge Time	6-7hours(with enough strong shine)								
Solar Cell	High efficiency imported silicon solar cell								
Light Source	SMD LED								
Operation Temp.	-40 to +45°C								
CCT	2700K SW / 3000K WW / 4100K NW / 5000K DW / 5700K CW								
Life Span	50,000 hours								
IP	65								
Beam Angle	120°								
Warranty	3Years								
Other	Mains complementary solar energy is available,pls contact sales for this function price.								

# DIMENSIONAL DRAWING

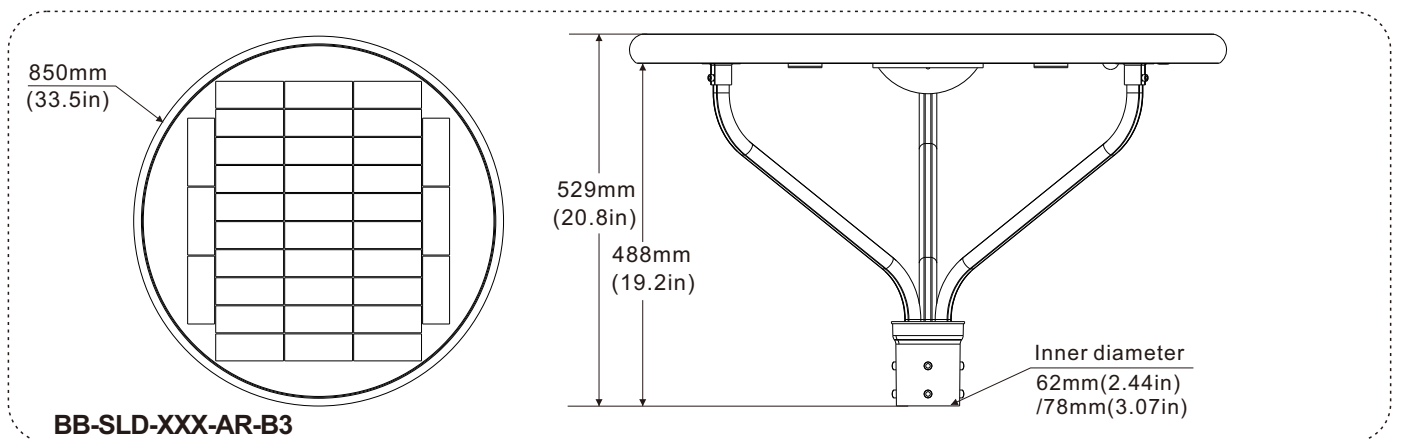
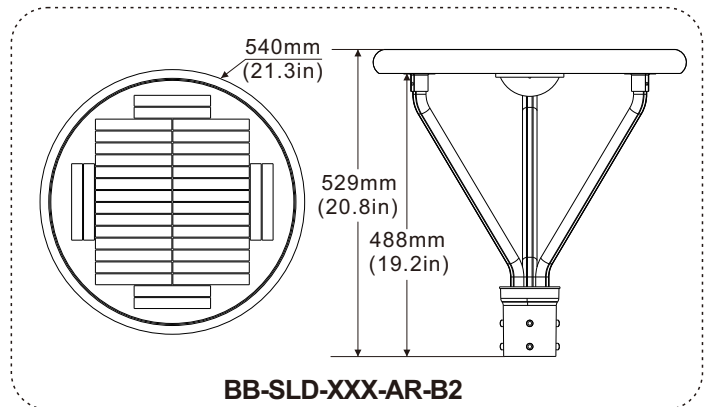
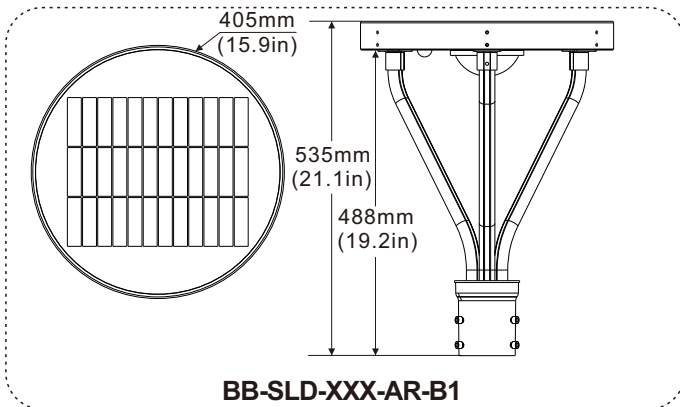

# WORKING CHARACTERISTICS

Default setting as below :

## Timer Control & PIR Sensor Control

- 1.If with insufficient ambient light,sensored dark,lamp will on. First Time Phase 4 hours ,  
When motion is detected,it will 100% brightness. When no motion detected after hold time 60s, and then switches to 30% brightness after stand-by period.
- 2.Second Time Phase 3 hours.When motion is detected,it will 70% brightness.  
When no motion detected after hold time 60s,and then switches to 30% brightness after stand-by period.
- 3.Third Time Phase 3 hours.When motion is detected,it will 50% brightness.  
When no motion detected after hold time 60s, and then switches to 30% brightness after stand-by period.
- 4.Forth Time Phase 6 hours.When motion is detected,it will 70% brightness.  
When no motion detected after hold time 60s,and then switches to 30% brightness after stand-by period.
- 5.While sensed daytime,lamp will off.

Note : IoT Smart Control , MPPT Smart Control all available in 20w 25w 40w 50w 80w 100w. If you need know more,pls contact salesman.

# PROJECTS

By using our 25W Area Light to replace 75W Metal Halide bulb for parking area lighting fixtures,the customer is now able to save a lot per month from his electric bill.



**25W LED = 75W MH**

## Note :

- Don't take the LED lamp apart.
- The LED lamp must work under the right voltage according to the specification.

# LUMINOUS INTENSITY DISTRIBUTION

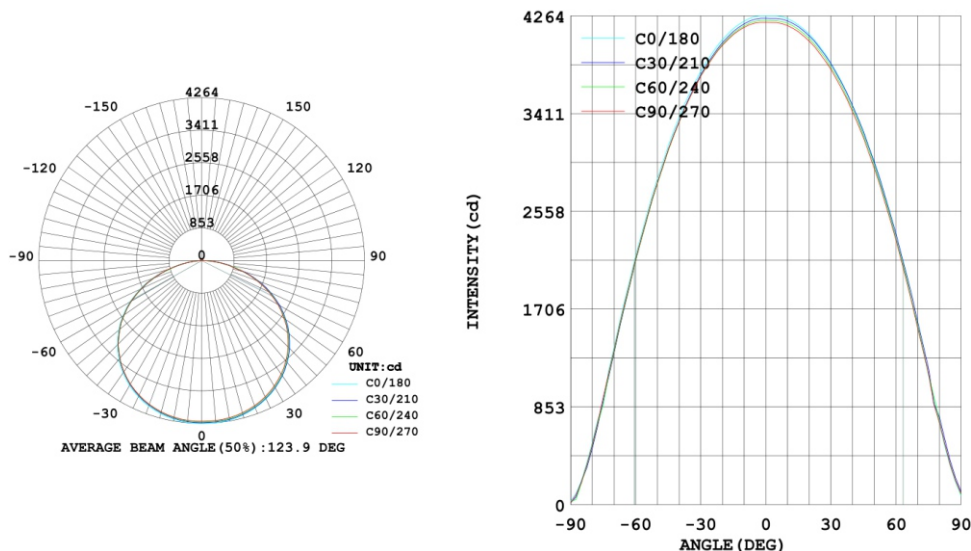

# ASSEMBLY

## Fixture assembly

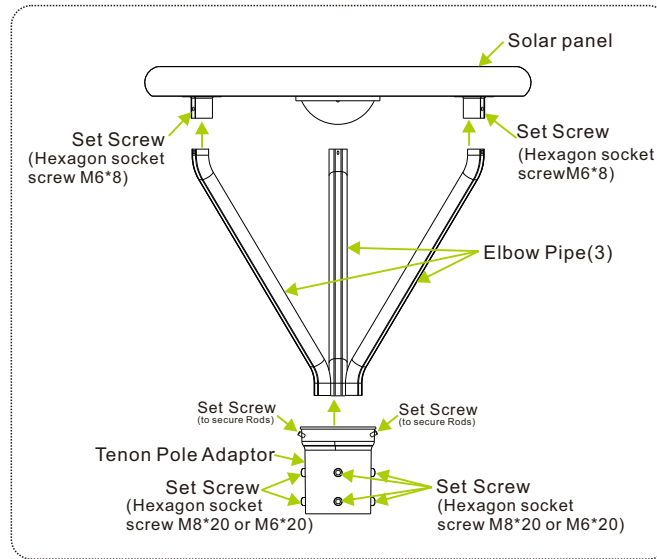

- Step1: Secure the elbow pipes to the lamp body with 3 screws(Hexagon socket screws M6\*8).
- Step2: Secure the Tenon Pole Adaptor and elbow pipes with 3 screws(Hexagon socket screws M6\*12).
- Step3: Check that all screws are not loose ,and then complete the fixture assembly.

## Assemble physical map



1. Above are all the accessories.

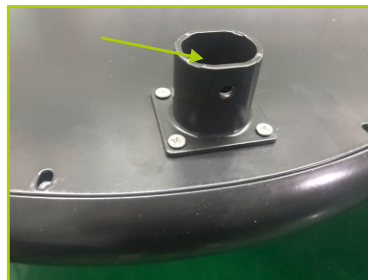

2. The lamp has three places where the elbow is installed.



3. Use a M6\*8 screw to secure a elbow pipe, a total of three elbow pipes.



4. Fix the elbow pipes with three M6\*12 screws.



5. If you only need 80mm (3.15in) tenon pole adaptor, use 6pcs M8\*20 screws to fix it, as shown above.



6. If you need 62mm (2.44in) tenon pole adaptor, use 3pcs washers and 6pcs M6\*20 screws to fix it.

# INSTALLATION

## Pole mounting(no wiring)

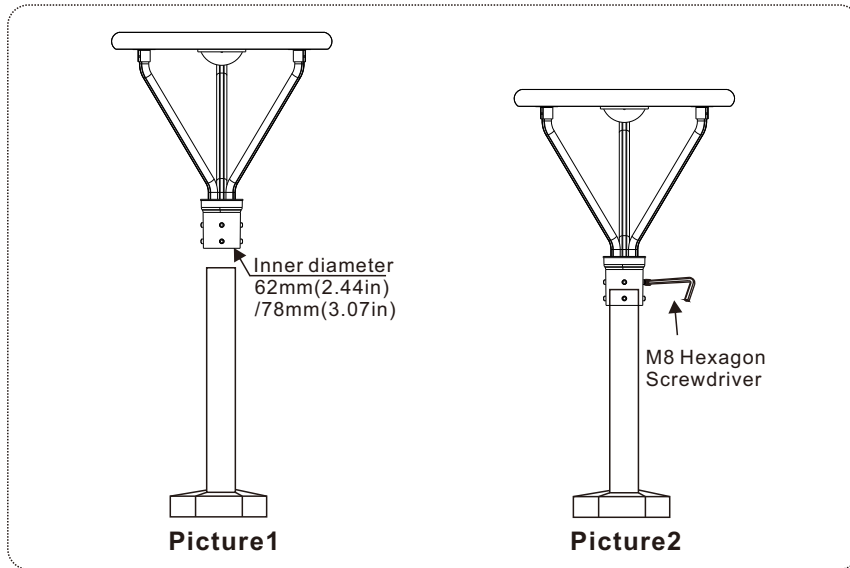

Step1: Turn off the power before installation.

Step2: Secure the Tenon Pole Adaptor and pole with 6 screws.

Step3: Check that all screws are not loose ,and then complete the pole mounting.

**The screws are different used for the different diameters of the rods.**

\*If you need 62mm (2.44in) tenon pole adaptor, you need to follow these steps before installing:



Figure1



Figure2



Figure3

1. When you receive the light, as shown in Figure 1. There are 3pcs washers and 6pcs M6\*20 screws. Pull the screws in the direction of the arrow.
2. When the screws and washers are in the position of Figure 2, place the lights into the pole.
3. Then tighten the screws as shown in Figure 3.

\*If you only need 80mm (3.15in) tenon pole adaptor, use 6pcs M8\*20 screws to fix it. Do not use M6\*20 screws and washers.

## Remote Control

The remote control is not provided by default, If you need, please contact sales.



If you want to know more details about the remote control, please read the remote control manual.

## Accessories

Optional: Anti-bird net

If necessary, please contact sales.

Function: Prevent birds from staying on the lamp and affect the work of the lamp.



## PACKING INFO



Item	Packaging	Carton Size(mm) (L*W*H)	N.W	G.W	Volume weight
B1:15W/20W/25W	1pc/CTN	480*480*170mm	6.5kg	8.0kg	8.0kg
B2:20W/25W/40W	1pc/CTN	590*590*170mm	9.2kg	10.5kg	12.0kg
B3:50W/80W/100W	1pc/CTN	920*920*180mm	18.2kg	19.9kg	31.0kg